

Stone: From Technique to Technology

Part One:
From Antiquity to the Romans



AD BONAM
FIDELI
PRISTINAMQUE
RESTITUTAM
A. S. MDCXXI







Technique vs Technology

Trial and Error vs Mathematics and Physics

Stonehenge
Wiltshire, England
Circa 3000 BCE



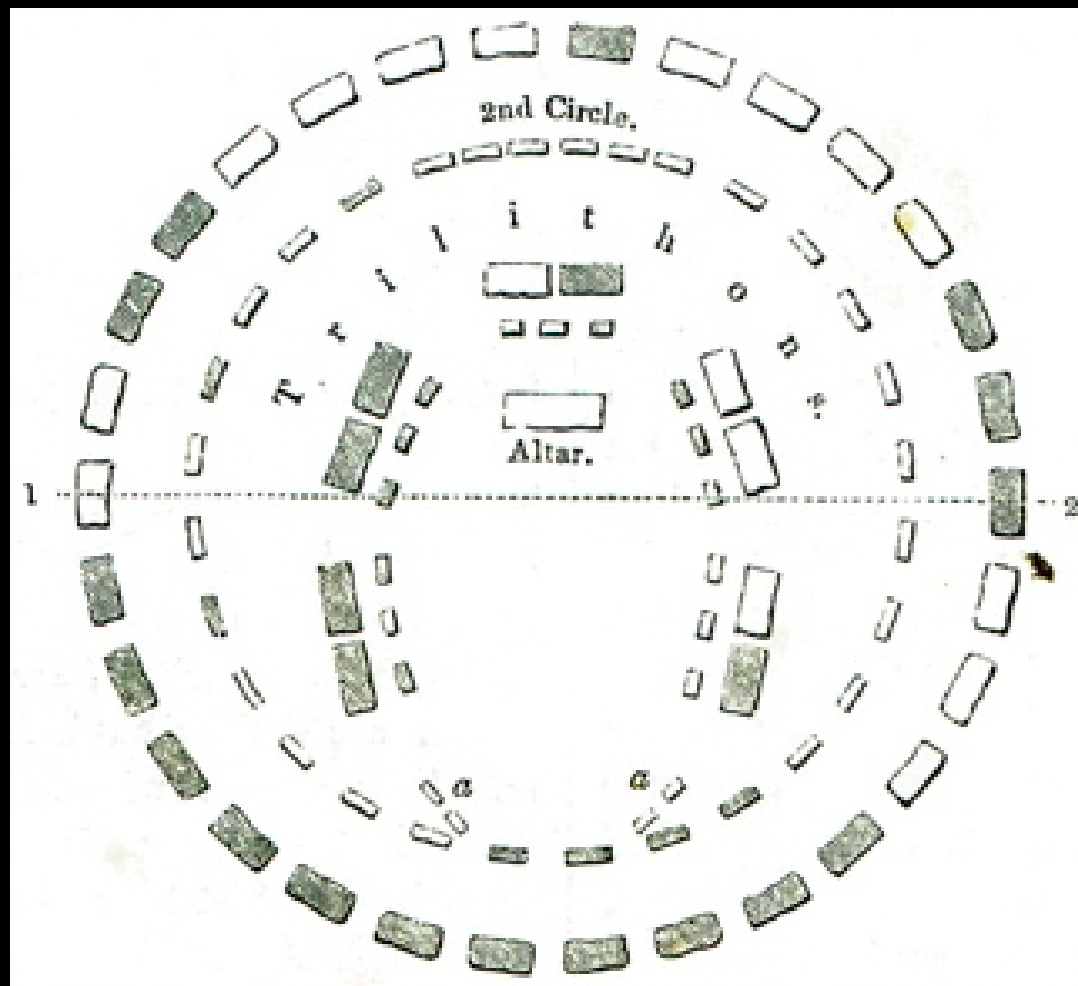

Law Code of Hammurabi
1750 BCE

If a builder build a house for a man and do not
make its construction firm,
and the house which he has built collapse
and cause the death of the owner of the house,
that builder shall be put to death.
If it cause the death of a son of the owner of the house,
they shall put to death a son of that builder.

ancient stone techniques

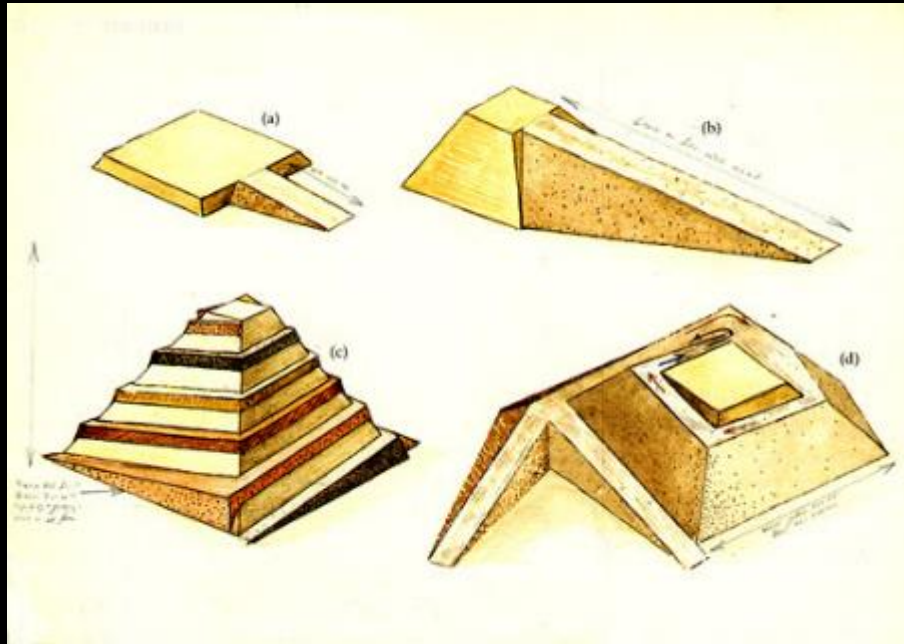



The Stepped Pyramid of Djoser at Saqqara
27th Century BCE

STEP PYRAMID OF ZOSER: SAKKARA

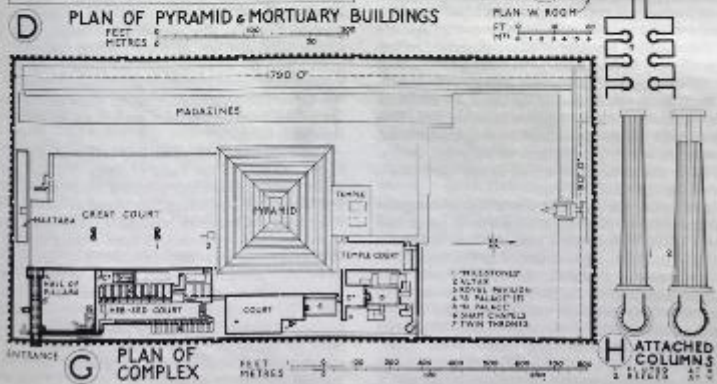
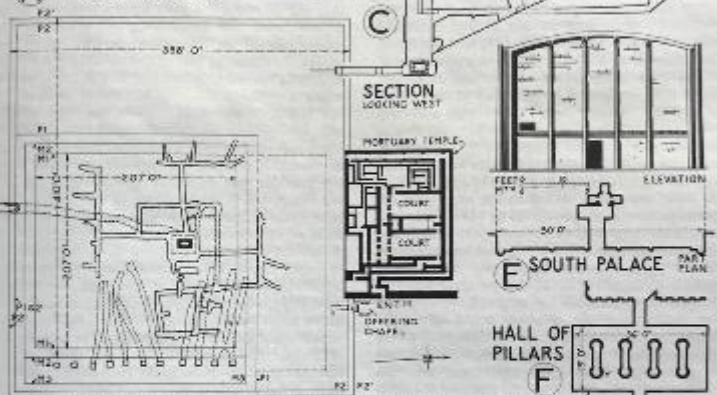
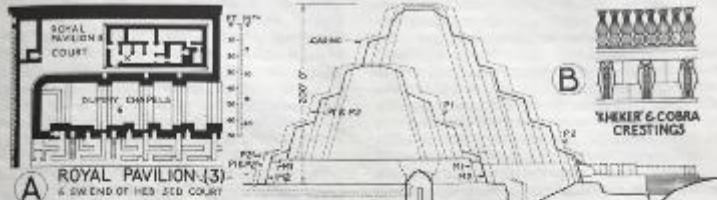







Pyramids at Giza
(Khufu/Cheops, Khafre/Chephren and Menkaure)
2580 BCE

PYRAMIDS AND ATTENDANT BUILDINGS

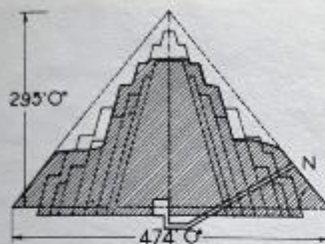

H PYRAMID AT ME SECTION
LOOKING WEST

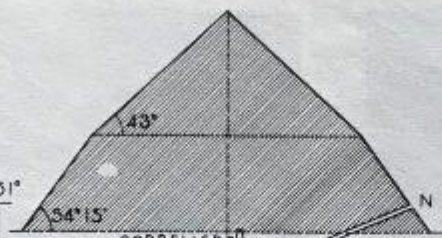

J 'BENT' PYRAMID: DASHÛR: SECTION
LOOKING WEST

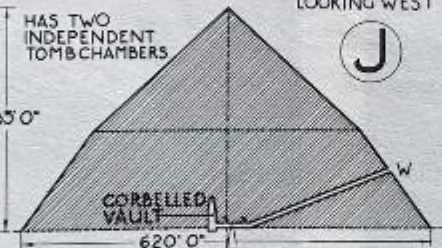

K 'BENT' PYRAMID: DASHÛR
SECTION
LOOKING SOUTH

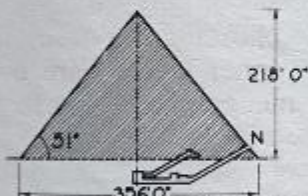

M PYR^d OF MYKERINOS
GIZEH SECTION
LOOKING WEST

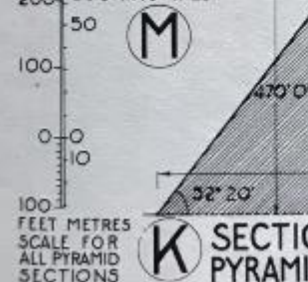

N SECTION
PYRAMID OF CHEPHREN GIZEH

FEET METRES
SCALE FOR
ALL PYRAMID
SECTIONS

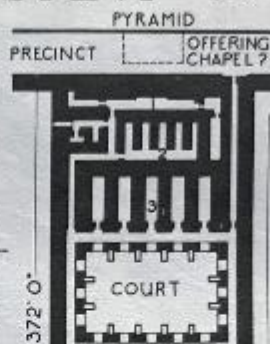

L MORTUARY TEMPLE & VALLEY
BUILDING OF CHEPHREN: GIZEH

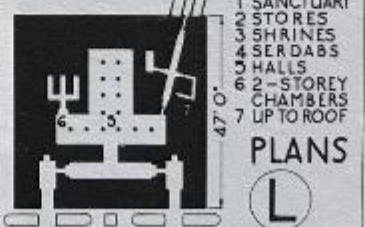

O PLANS
MORTUARY TEMPLE & VALLEY
BUILDING OF CHEPHREN: GIZEH



P DETAIL OF
TOMB
CHAMBER
LOOKING W

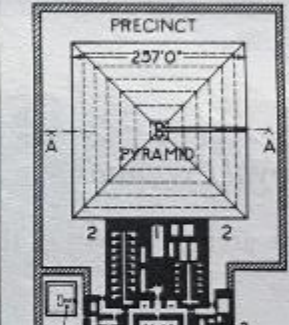

Q SECTION 'AA'
PYRAMID COMPLEX
OF SAHURA: ABUSTR

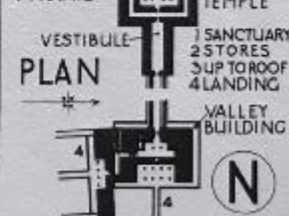

R PLAN
PYRAMID COMPLEX
OF SAHURA: ABUSTR

- 1 SANCTUARY
- 2 STORES
- 3 SHRINES
- 4 SER DABS
- 5 HALLS
- 6 2-STOREY CHAMBERS
- 7 UP TO ROOF

S PLAN
MINOR PYRAMID
MORTUARY TEMPLE
VALLEY BUILDING

T PLAN
MINOR PYRAMID
MORTUARY TEMPLE
VALLEY BUILDING

U PLAN
MINOR PYRAMID
MORTUARY TEMPLE
VALLEY BUILDING

V PLAN
MINOR PYRAMID
MORTUARY TEMPLE
VALLEY BUILDING

W PLAN
MINOR PYRAMID
MORTUARY TEMPLE
VALLEY BUILDING

X PLAN
MINOR PYRAMID
MORTUARY TEMPLE
VALLEY BUILDING

Y PLAN
MINOR PYRAMID
MORTUARY TEMPLE
VALLEY BUILDING







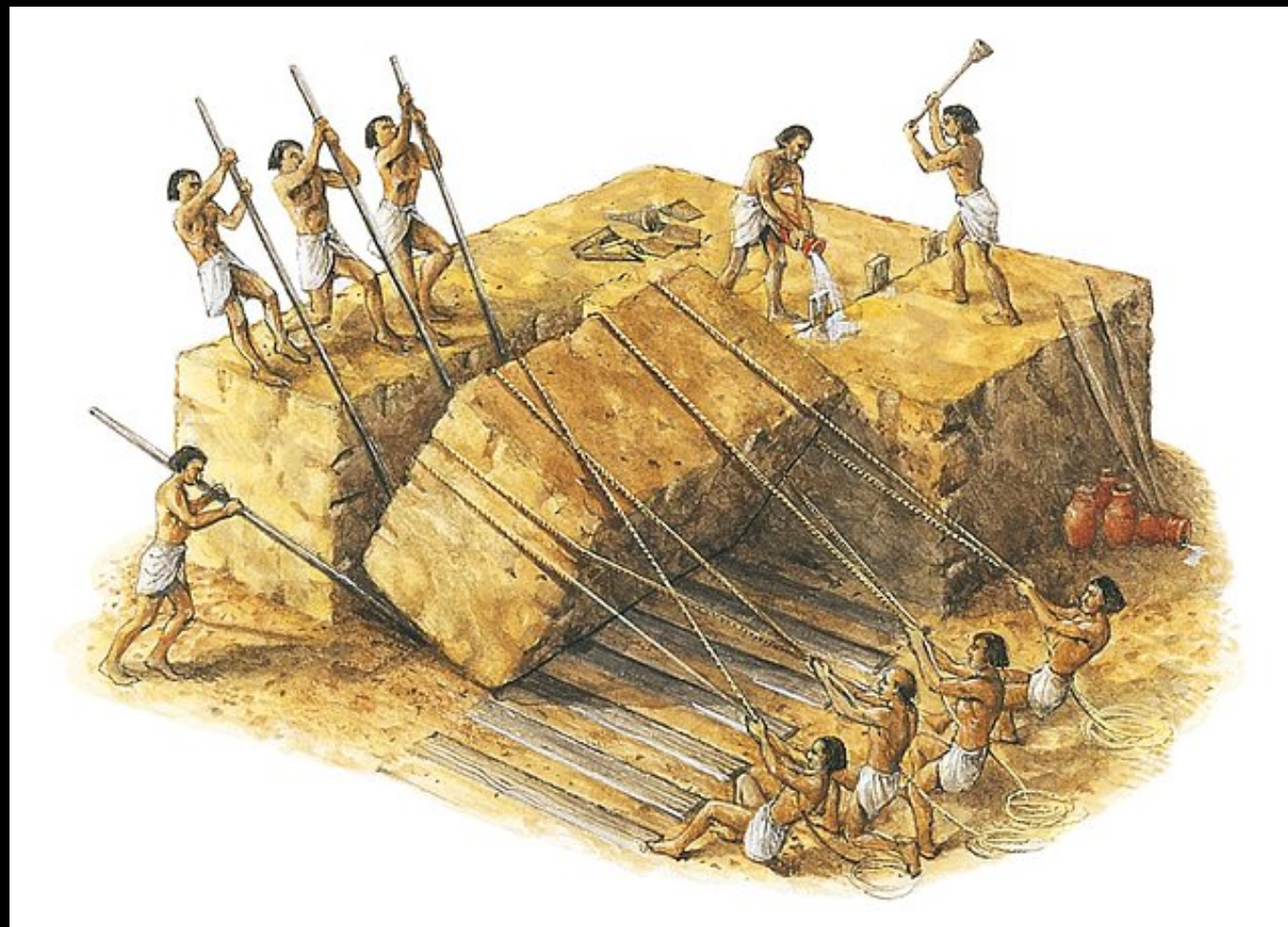



Temple at Karnak
Thebes, Egypt
2050 BCE



Hypostyle Hall

Where the roof is supported by a sea of closely spaced columns









STONE CANNOT SPAN!
IT HAS ZERO TENSILE ABILITY





Mortuary Temple of Hatshepsut
Valley of the Queens, Egypt
1479 BCE















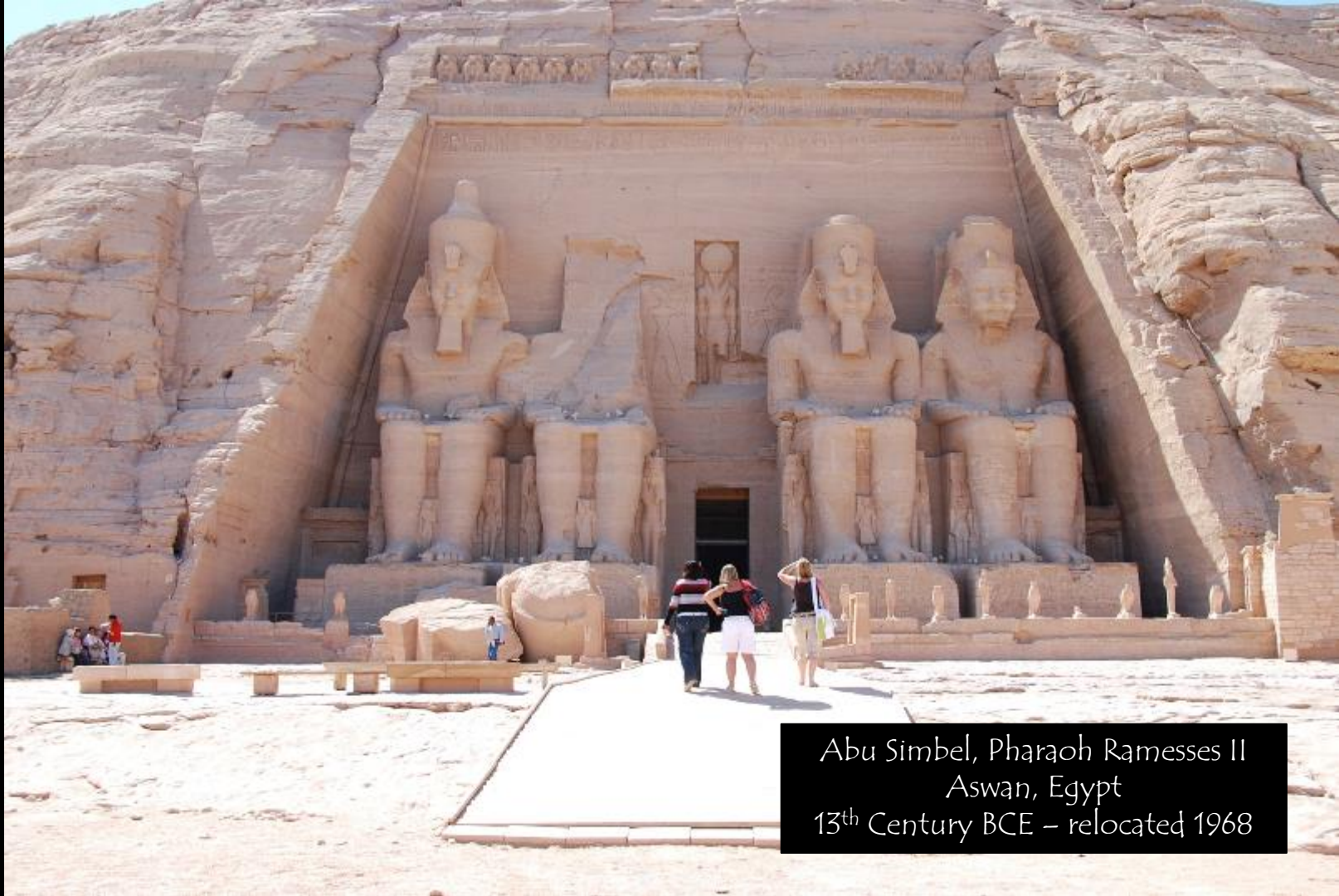

Abu Simbel, Pharaoh Ramesses II
Aswan, Egypt
13th Century BCE – relocated 1968













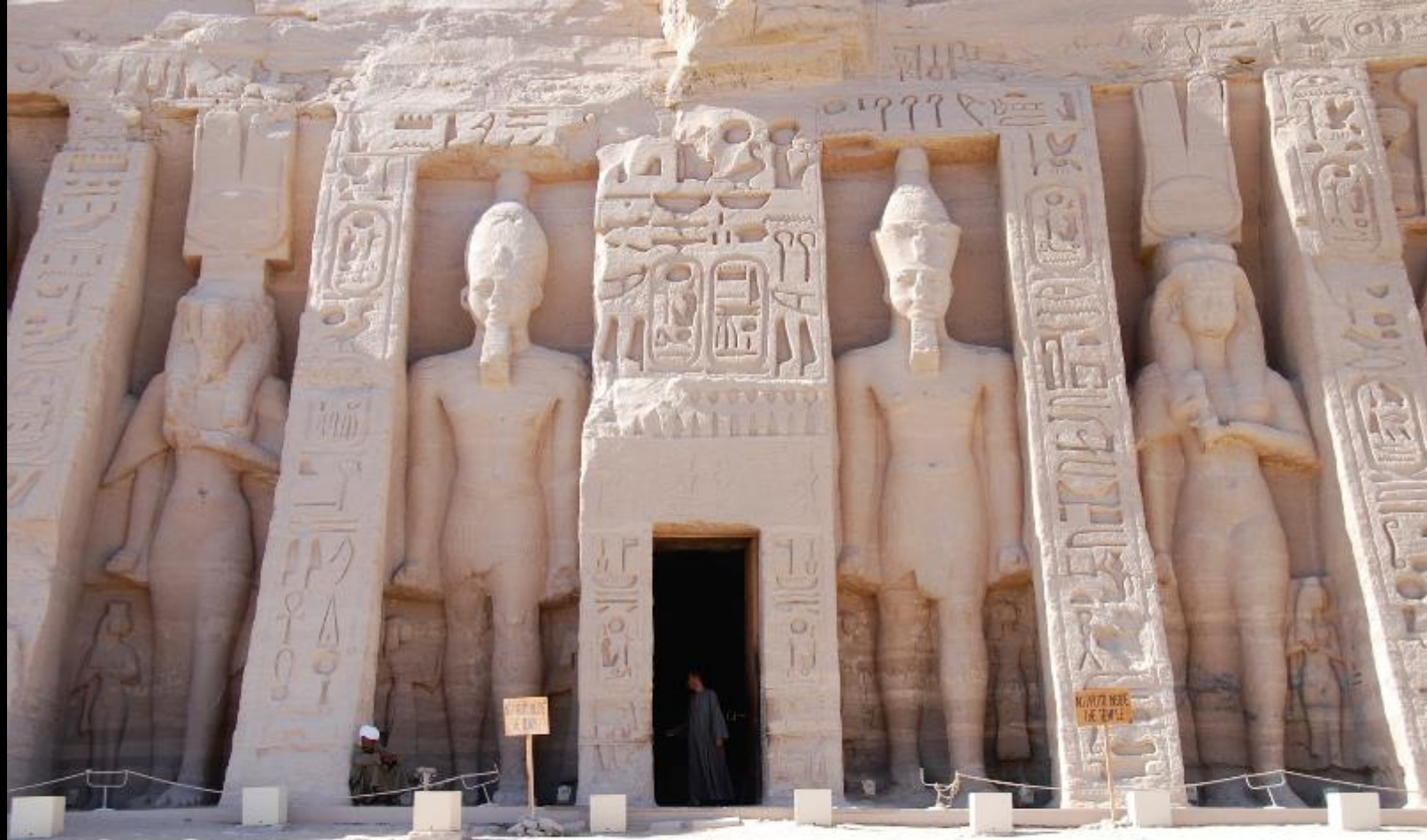



NO PHOTO INSIDE
THE TEMPLE





Tomb of Ramesses III
Valley of the Kings, Egypt
1155 BCE





3. Ägyptische Säulenkapitelle von Philae.



The Temple of Isis at Philae
Aswan, Egypt
380 BCE













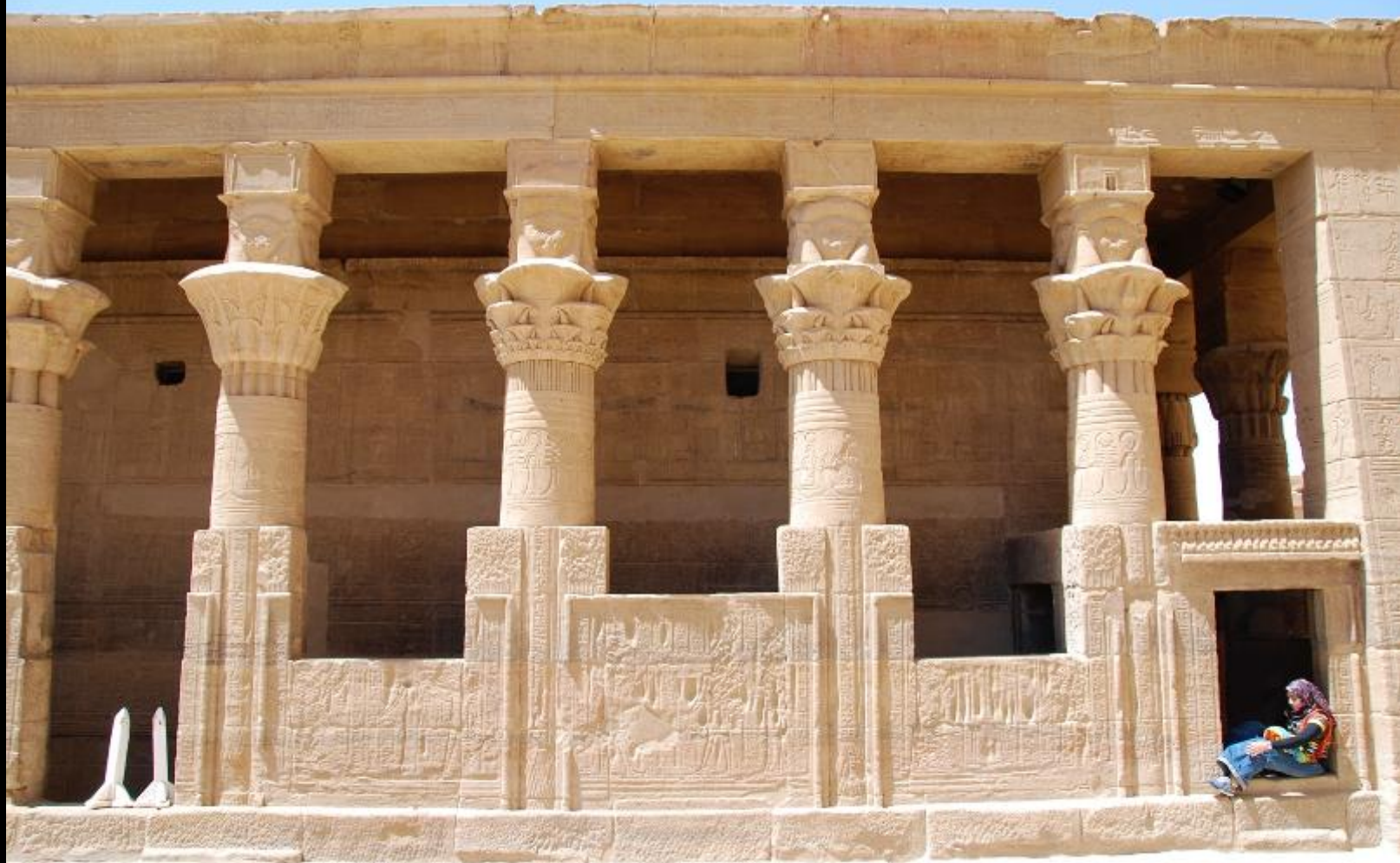















The Temple of Horus at Edfu
Ptolemaic Kingdom
237 BCE



























Lion Gate
Bronze Age Citadel
Mycenae, Greece
1250 BCE















TREASURY OF ATREUS:
MYCENÆ.

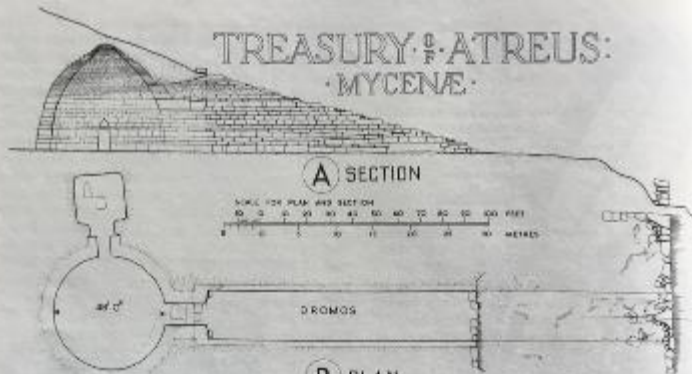

B PLAN

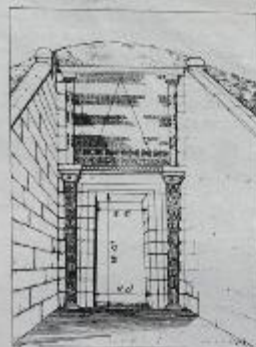

D

PORTION OF SHAFT

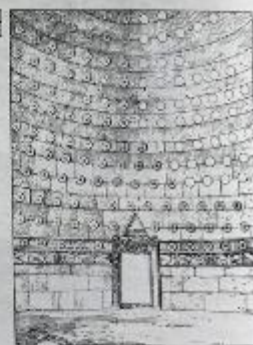

E INTERIOR RESTORED

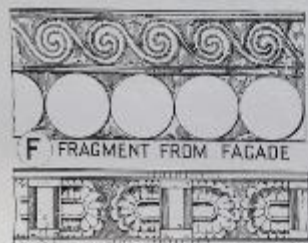

G FRAGMENT FROM FACADE



H SCULPTURE, GATE OF LIONS, MYCENÆ











Great Wall of China
From 7th Century BCE









Four main Classical Column Styles

Doric

Ionic

Corinthian

Composite

EVOLUTION OF A DORIC ORDER

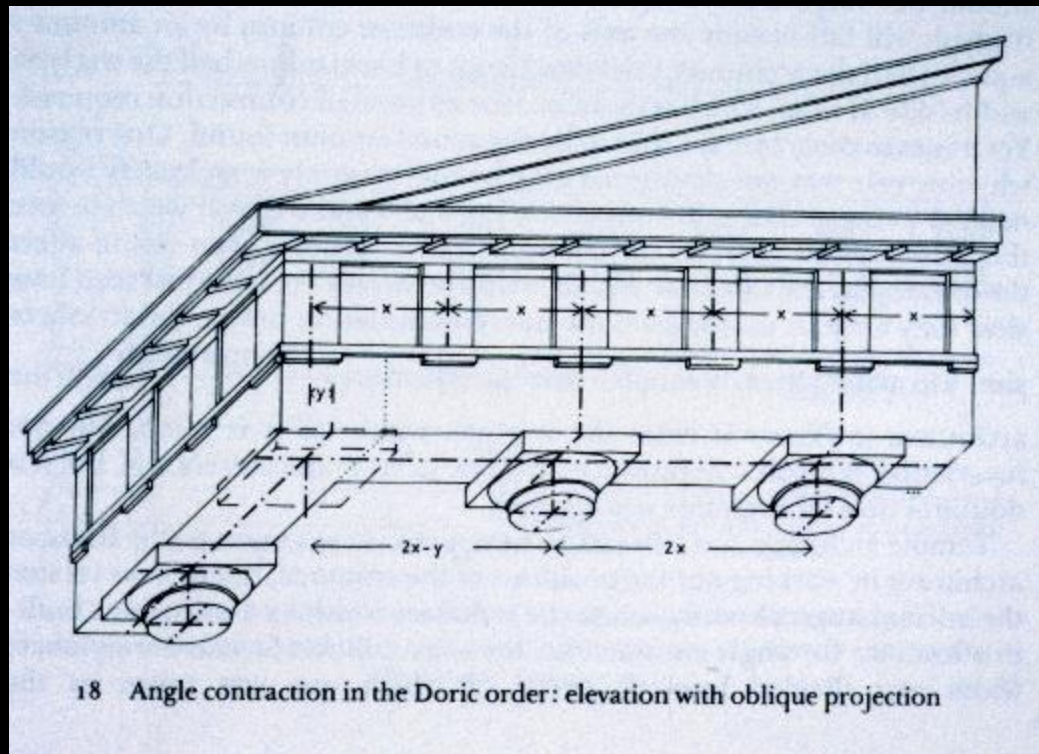
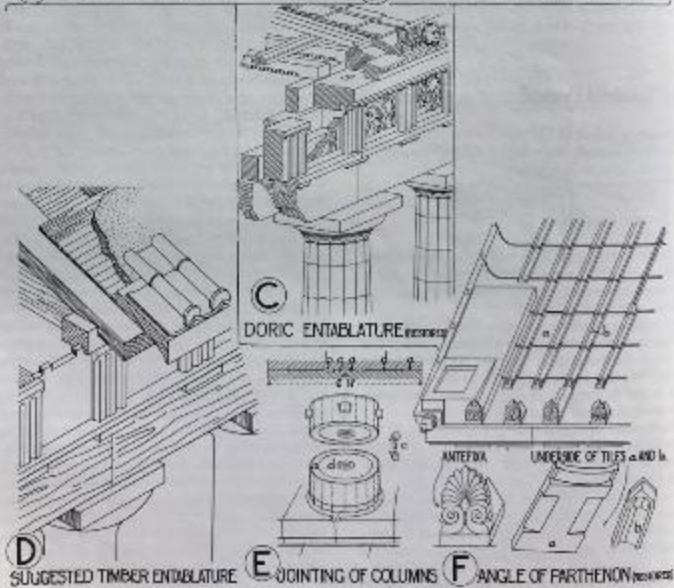
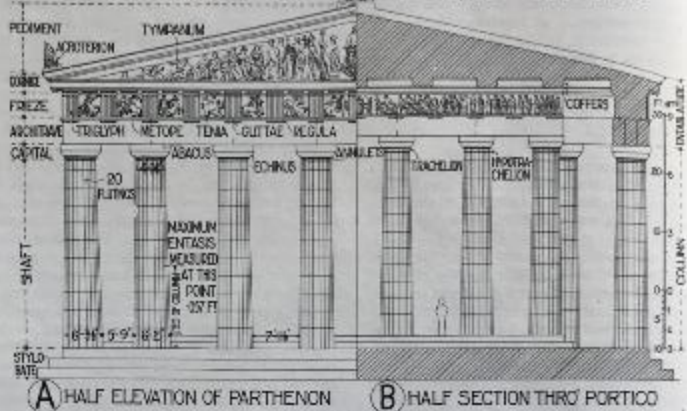

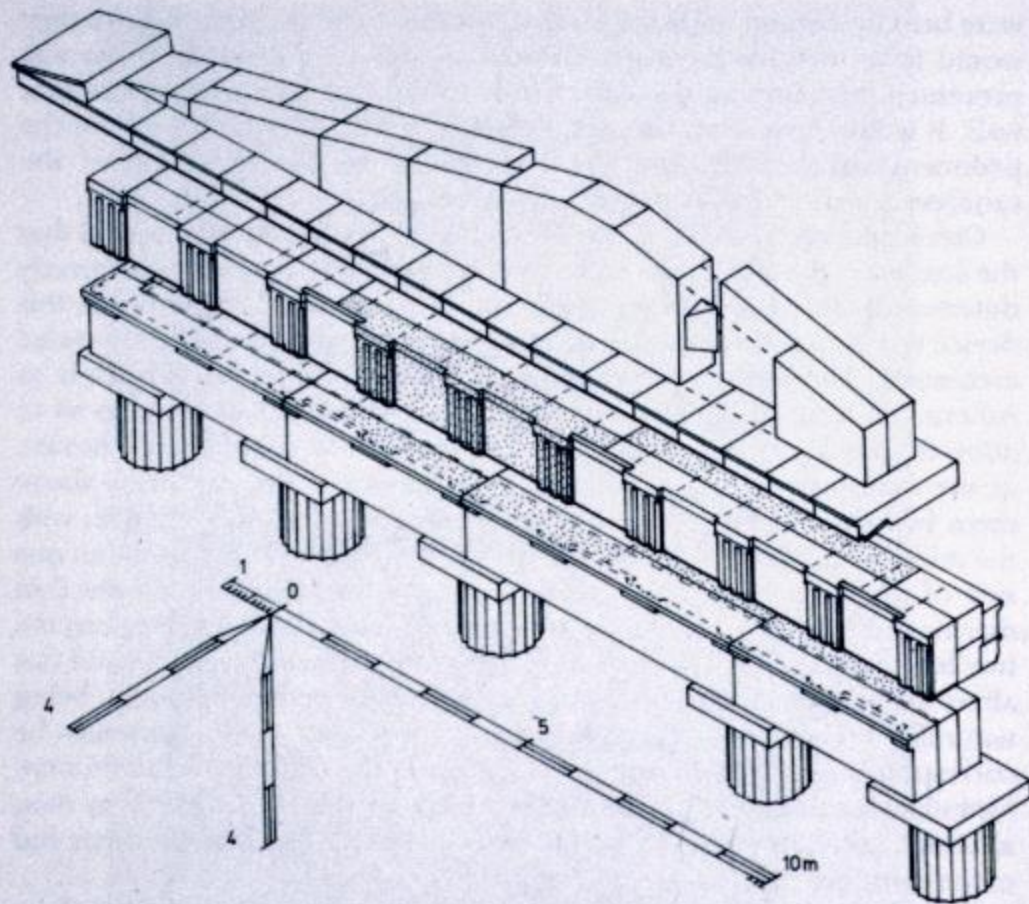

67 Propylaea at Athens, east façade (c. 437–432 B.C.): exploded isometric view showing cantilevered frieze beams

THE DORIC ORDER

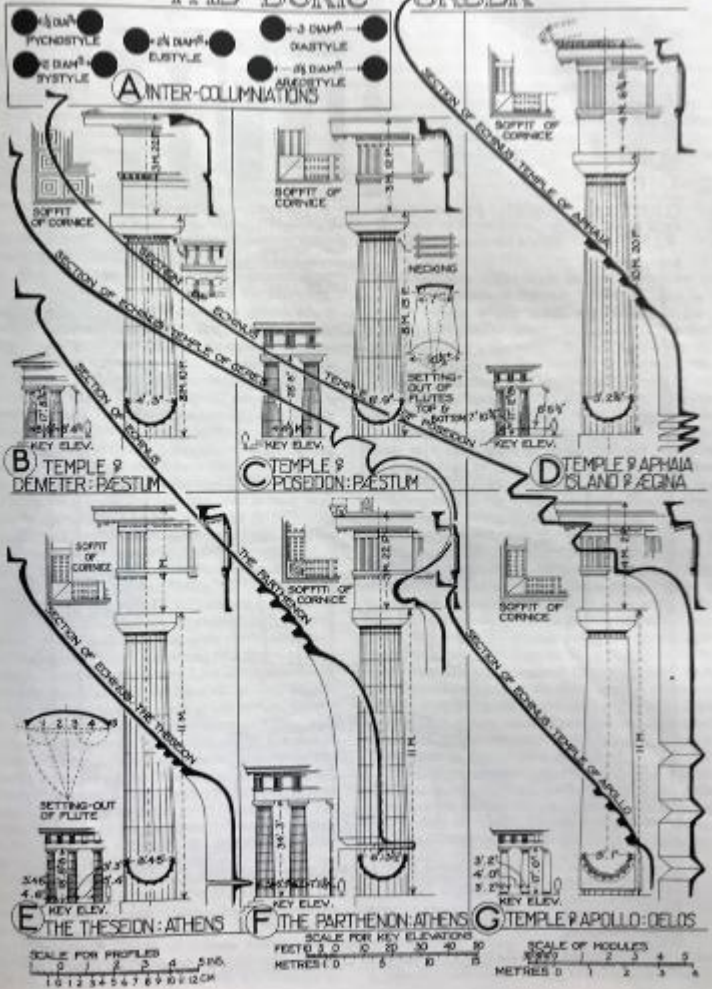



Temple of Apollo
Ancient Corinth,
Greece
550 BCE





THE IONIC VOLUTE

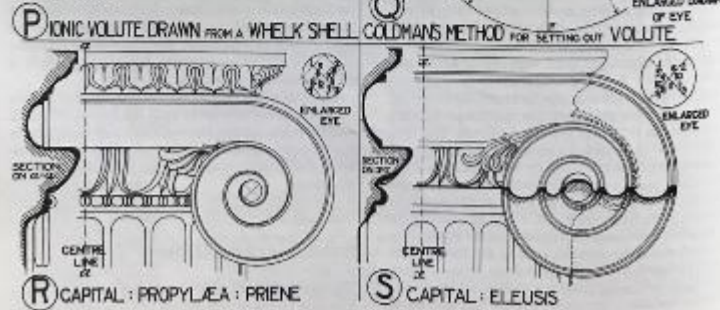
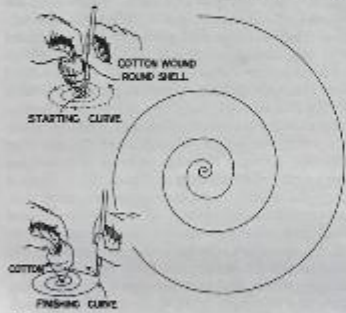
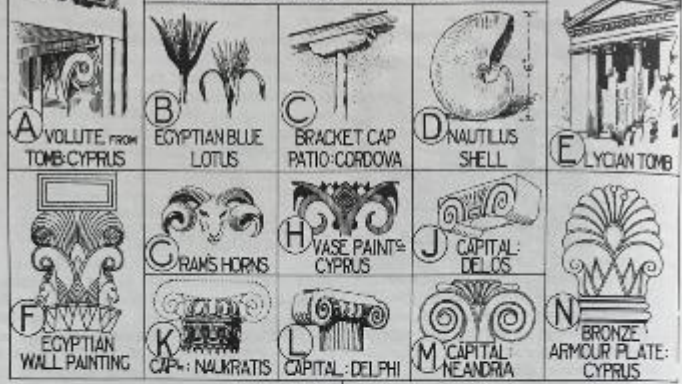

THE IONIC ORDER

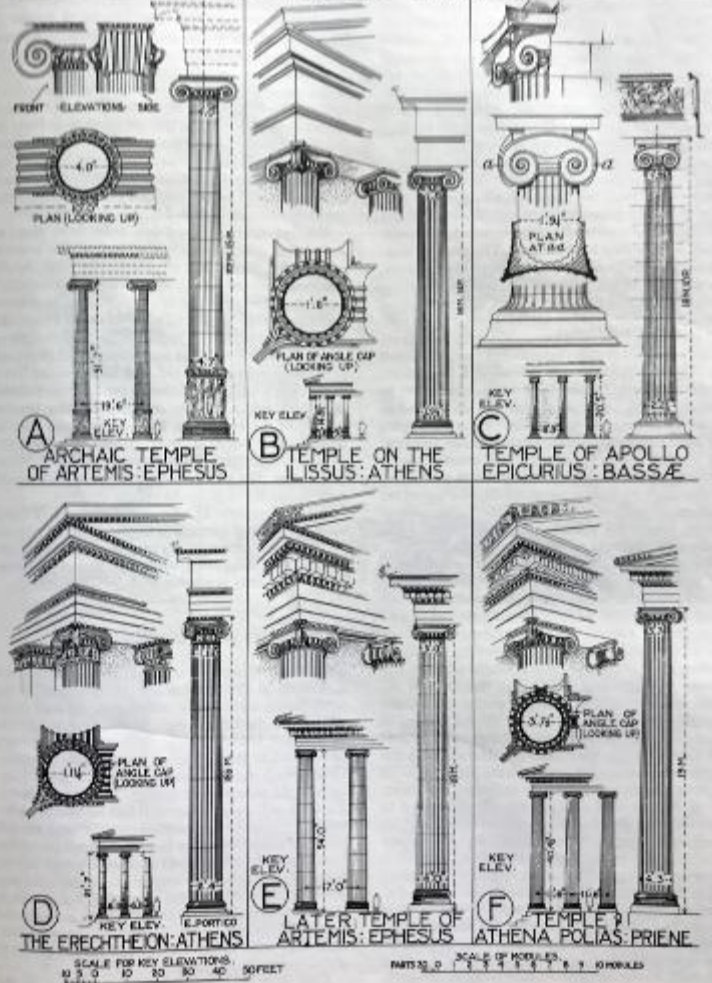

SCALE FOR KEY ELEVATIONS: 0 10 20 30 40 50 FEET
 PARTS: 0 1 2 3 4 5 6 7 8 9 10 11 12 13 14 15 16 17 18 19 20 21 22 23 24 25 26 27 28 29 30 31 32 33 34 35 36 37 38 39 40 41 42 43 44 45 46 47 48 49 50 51 52 53 54 55 56 57 58 59 60 61 62 63 64 65 66 67 68 69 70 71 72 73 74 75 76 77 78 79 80 81 82 83 84 85 86 87 88 89 90 91 92 93 94 95 96 97 98 99 100





W. A. Webb
ACANTHUS COLUMN



KIONOKPANON
META XIMAIPON
CHIMAERA CAPITAL



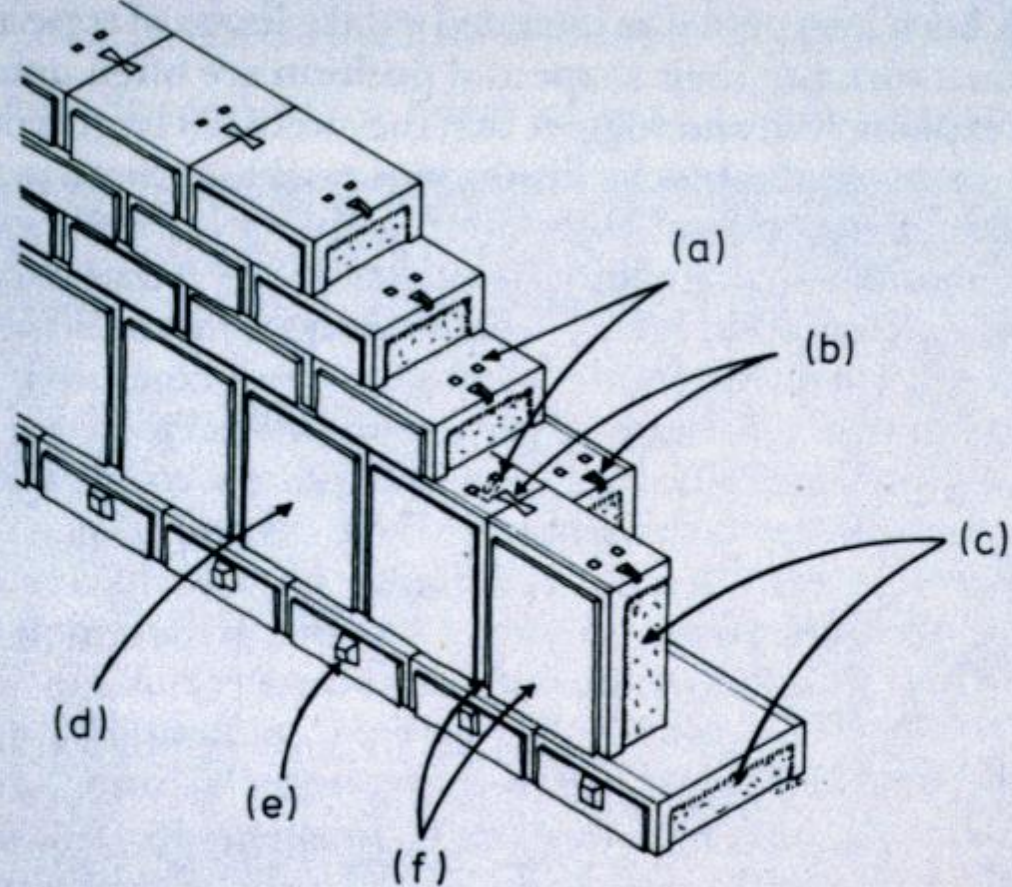

12 Features of early Greek monumental masonry: (a) U-shaped hole; (b) dove-tail clamp; (c) band anathyrosis; (d) orthostate; (e) handling boss; (f) preliminary dressing

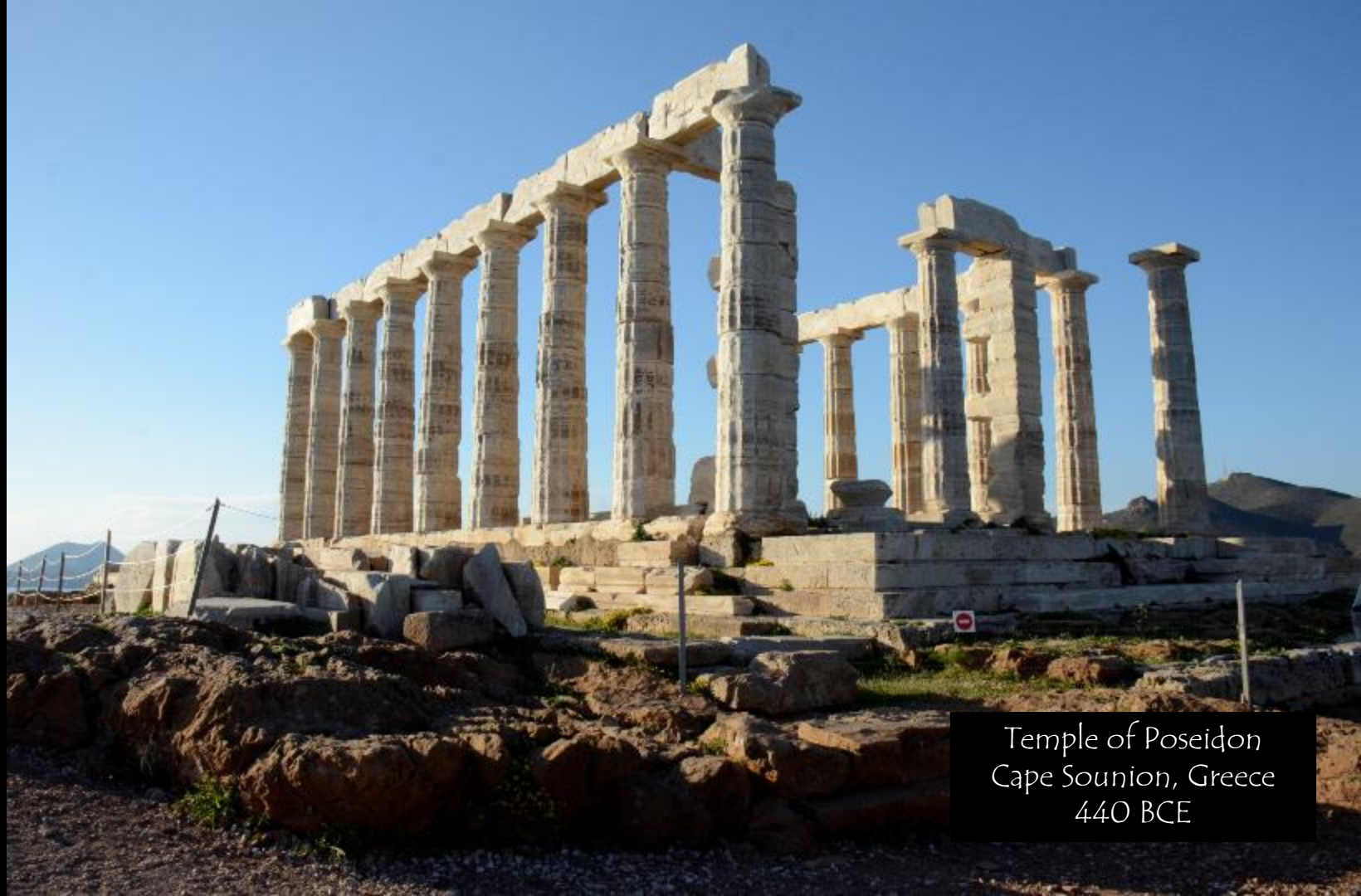

Temple of Poseidon
Cape Sounion, Greece
440 BCE





Delphi Theatre
Greece
4th Century BCE



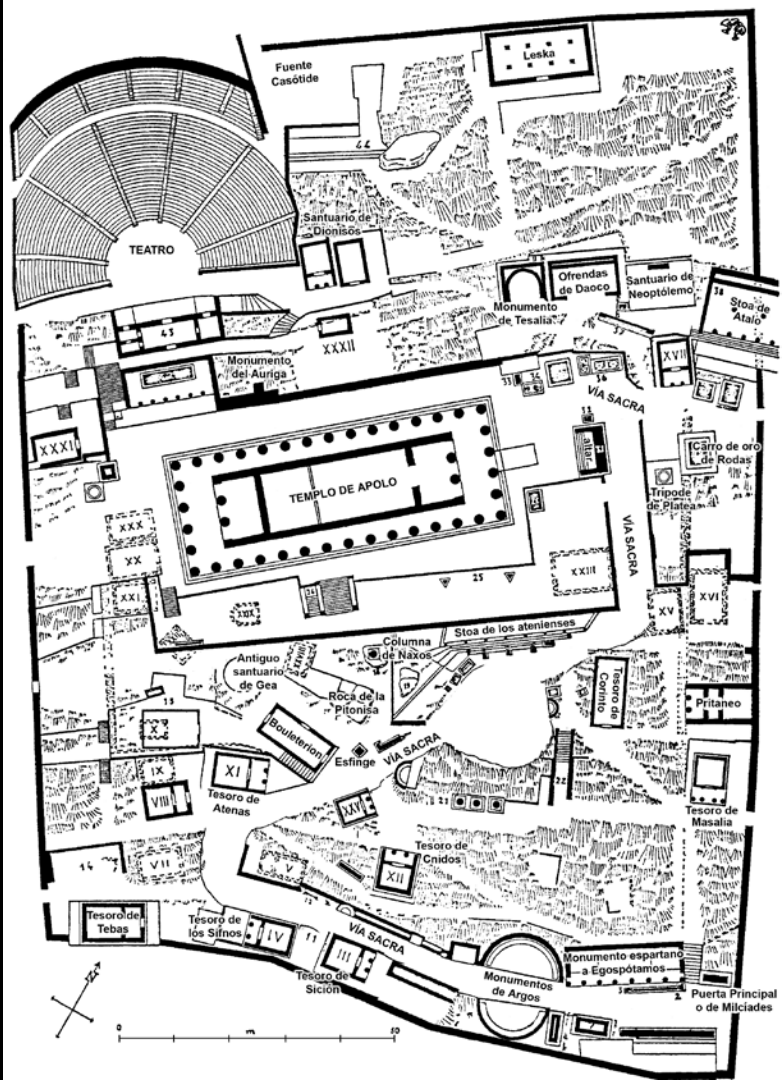



Acropolis
Athens, Greece
Circa 500 BCE

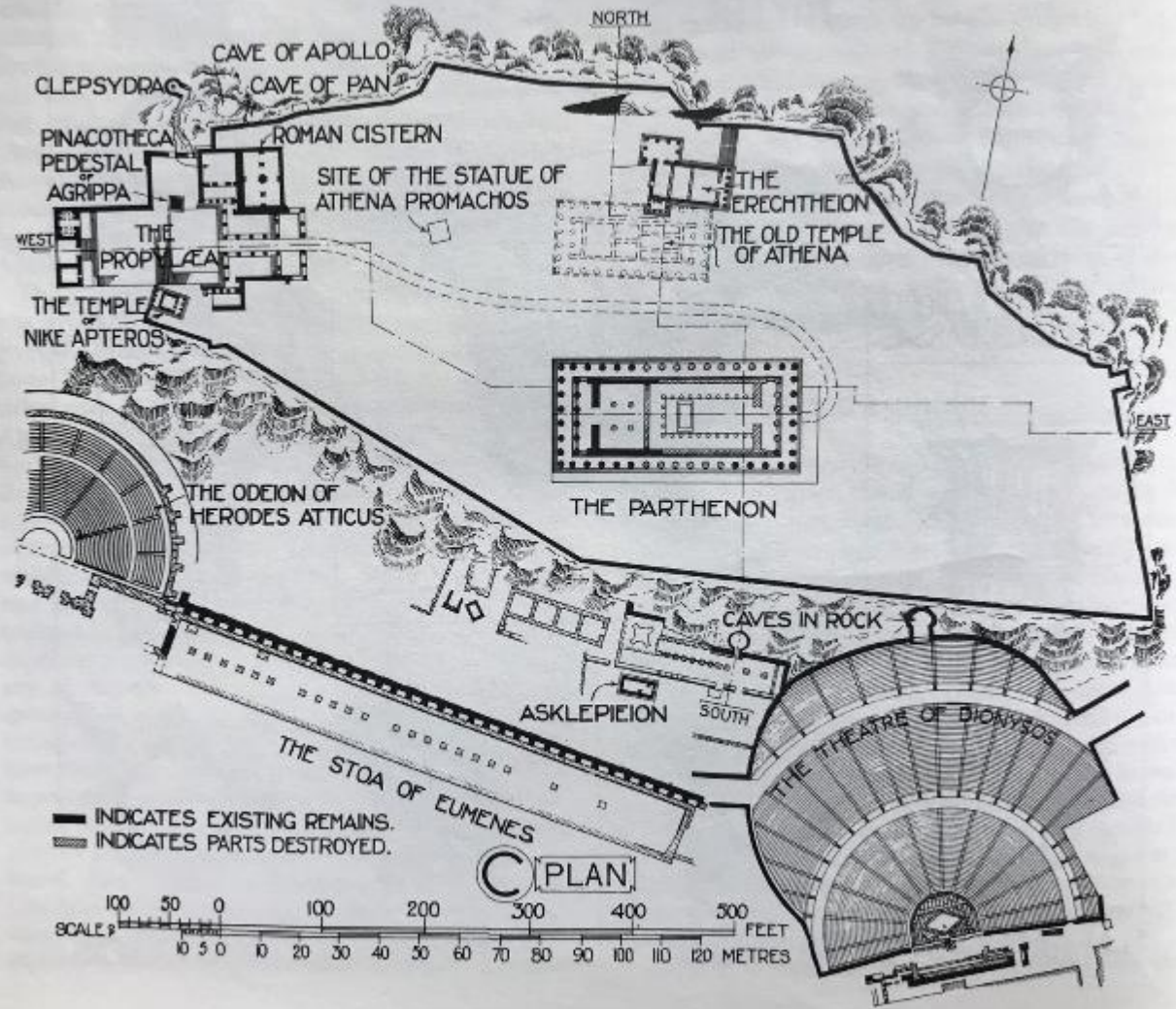

PLAN























The Parthenon
Acropolis
Athens, Greece
Circa 500 BCE

THE PARTHENON, ATHENS



A SECTIONAL VIEW OF E. END

B E. FACADE (RESTORED)

C N.W. ANGLE (RESTORED)



D E. ELEVATION (RESTORED)



E HALF TRANSVERSE SECTION THRO' NAOS + THRO' PARTHENON

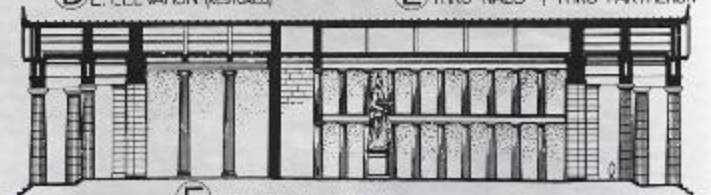

F LONGITUDINAL SECTION (RESTORED)

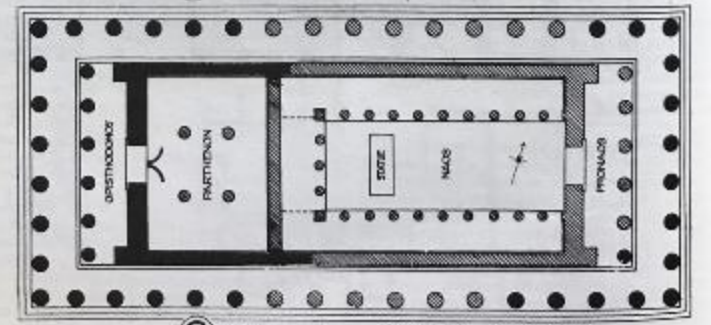

G PLAN (RESTORED)

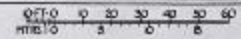



















Erechtheum
Acropolis
Athens, Greece
Circa 500 BCE

THE ERECHTHEION : ATHENS



A VIEW FROM NORTH WEST

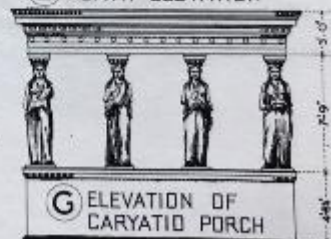
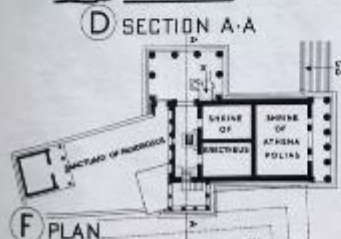
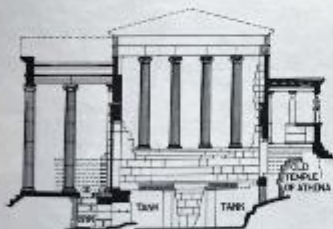

0 10 20 30 40 50 60 70 80 90 100 FEET
0 1 2 3 4 5 6 7 8 9 10 METERS
SCALE FOR ELEVATIONS & SECTIONS. SCALE FOR PLAN











PAESTUM

Planis (area archeologica)
 Con la localizzazione del
 sito a Vietri sul Mare
 (SA) - Campania

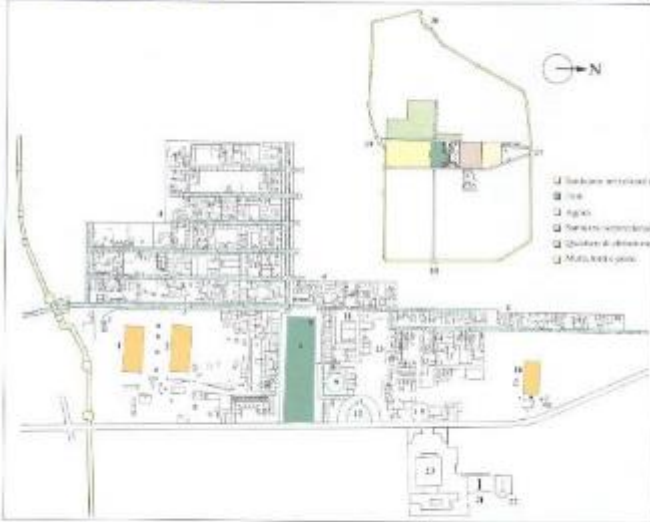

- | | | | |
|----------------------------|-----------------------|--------------------------------------|-----------------------------|
| 1. Anfiteatro | 7. Circo | 13. Tempio monumentale del fuggiasco | 19. Ponte Clavatore |
| 2. Anfiteatro di Nettuno | 8. Mosaico | 14. Sordani - Stregoni | 20. Ponte Marone |
| 3. "La Rocca" | 9. Campidoglio | 15. Sordani | 21. Acquedotto di Sordani |
| 4. Quartiere di abitazione | 10. Tempio di Nettuno | 16. Tempio di Nettuno | 22. Sordani - Stregoni |
| 5. Foro | 11. Piazza | 17. Ponte Sordani | 23. Mura e mura perimetrali |
| 6. Colonna | 12. Anfiteatro | 18. Ponte Sordani | 24. Mura e mura perimetrali |

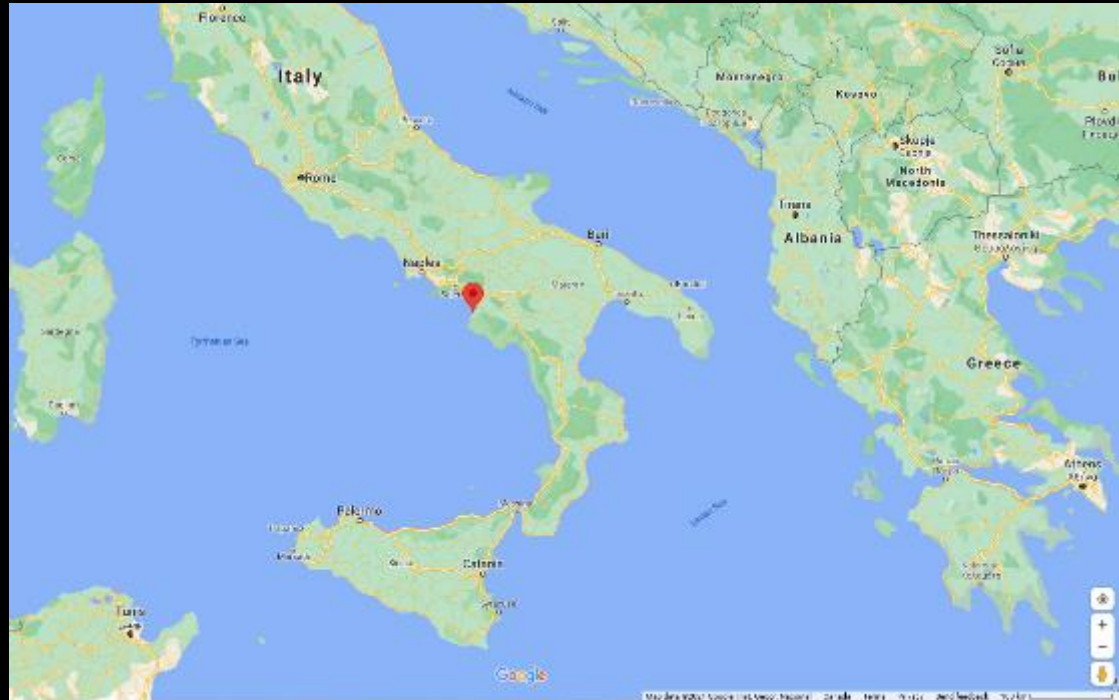



First Temple of Hera
Paestum, Italy
550 BCE





Second Temple of Hera
Paestum, Italy
450 BCE





VITRUVIUS
THE TEN BOOKS
ON ARCHITECTURE

TRANSLATED BY MORRIS HICKY MORGAN
68 ILLUSTRATIONS

CHAPTER I

THE EDUCATION OF THE ARCHITECT

1. THE architect should be equipped with knowledge of many branches of study and varied kinds of learning, for it is by his judgement that all work done by the other arts is put to test. This knowledge is the child of practice and theory. Practice is the continuous and regular exercise of employment where manual work is done with any necessary material according to the design of a drawing. Theory, on the other hand, is the ability to demonstrate and explain the productions of dexterity on the principles of proportion.

2. It follows, therefore, that architects who have aimed at acquiring manual skill without scholarship have never been able to reach a position of authority to correspond to their pains, while those who relied only upon theories and scholarship were obviously hunting the shadow, not the substance. But those who have a thorough knowledge of both, like men armed at all points, have the sooner attained their object and carried authority with them.

3. In all matters, but particularly in architecture, there are these two points: — the thing signified, and that which gives it its significance. That which is signified is the subject of which we may be speaking; and that which gives significance is a demonstration on scientific principles. It appears, then, that one who professes himself an architect should be well versed in both directions. He ought, therefore, to be both naturally gifted and amenable to instruction. Neither natural ability without instruction nor instruction without natural ability can make the perfect artist. Let him be educated, skilful with the pencil, instructed in geometry, know much history, have followed the philosophers with attention, understand music, have some knowledge of medi-

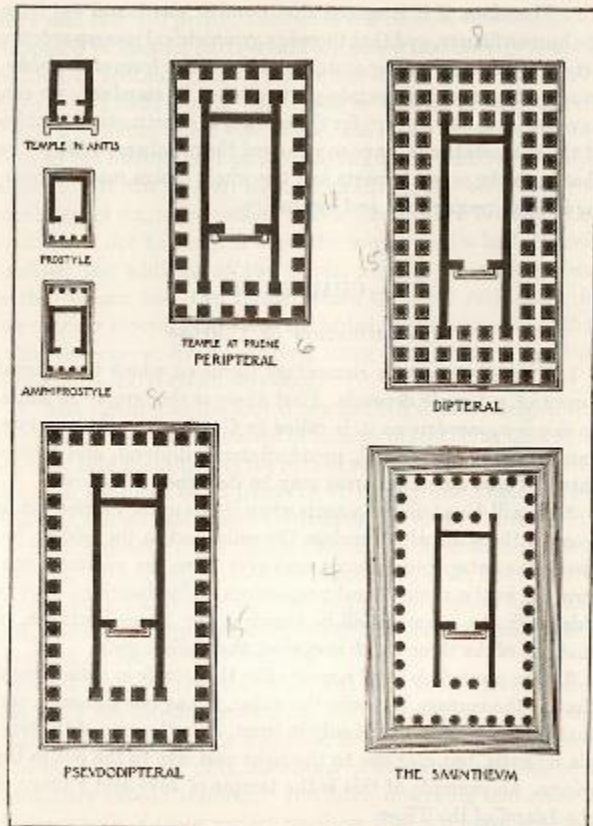

THE CLASSIFICATION OF TEMPLES ACCORDING TO THE ARRANGEMENTS OF THE COLONNADES

umns. Let the columns be so placed as to leave a space, the width of an intercolumniation, all round between the walls and the rows of columns on the outside, thus forming a walk round the cells of

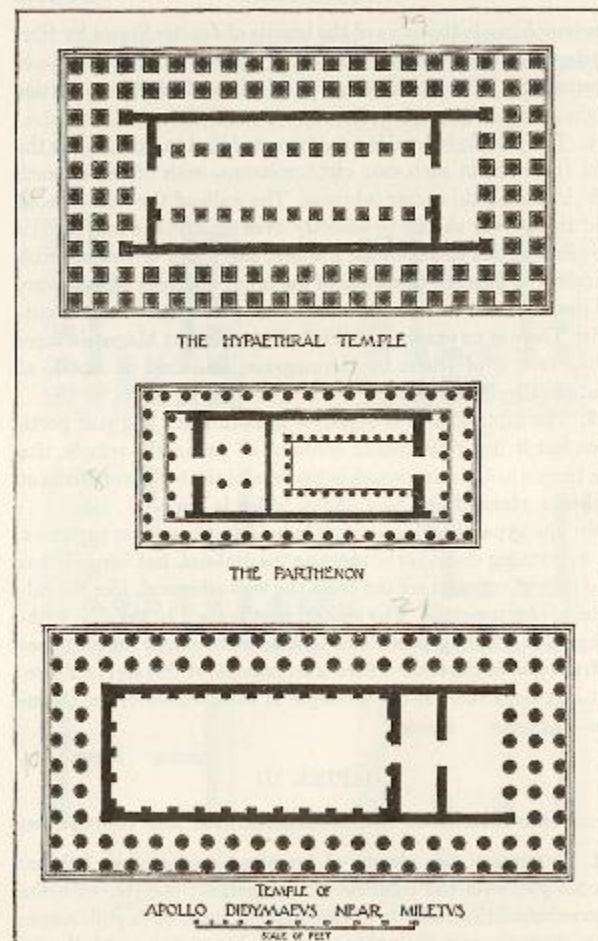

THE HYPÆTHRAL TEMPLE OF VITRUVIUS COMPARED WITH THE PARTHENON AND THE TEMPLE OF APOLLO NEAR MILETUS

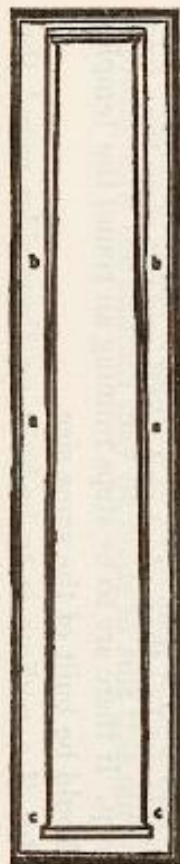

1

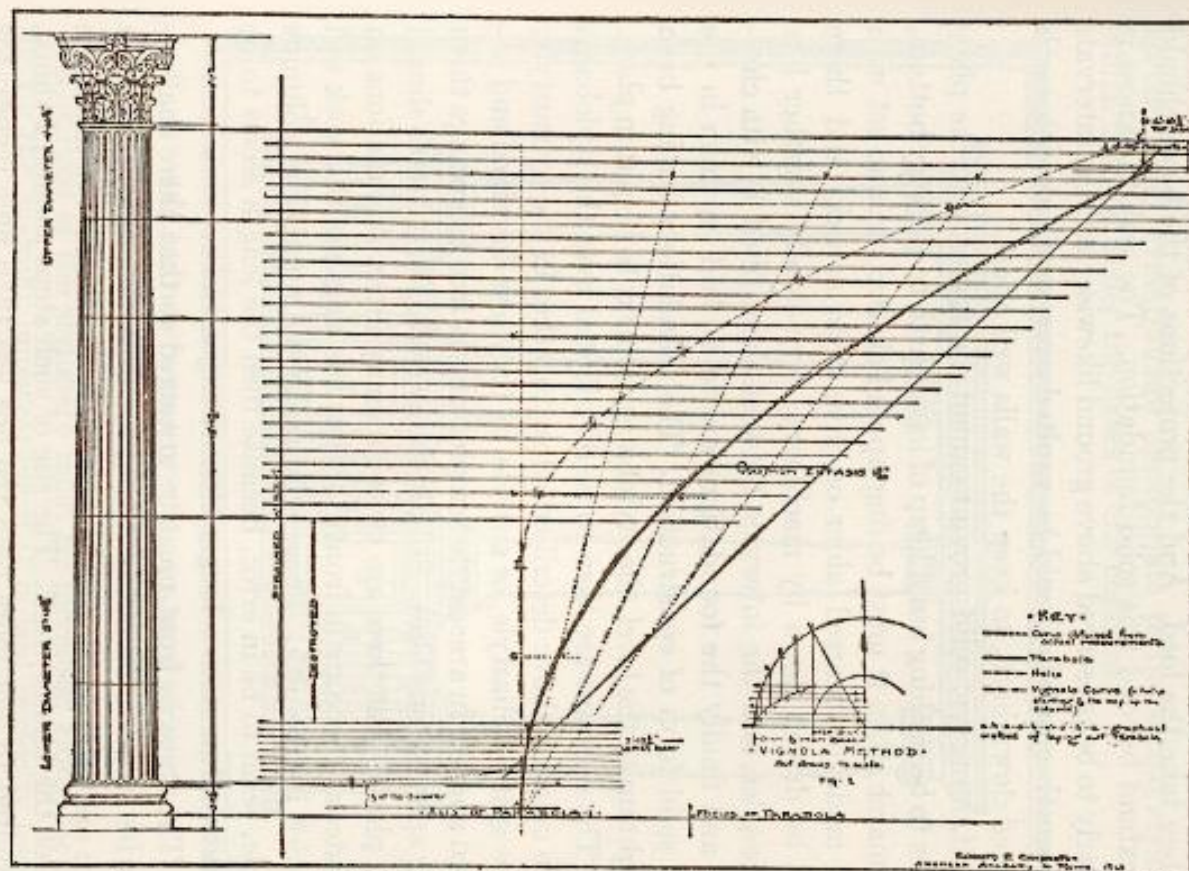

2

THE ENTASIS OF COLUMNS

1. The entasis as given by Fra Giocondo in the edition of 1511.
2. The entasis from the temple of Mars Ultor in Rome compared with Vignola's rule for entasis.

2. The pycnostyle is a temple in an intercolumniation of which the thickness of a column and a half can be inserted: for example, the temple of the Divine Cæsar, that of Venus in Cæsar's forum, and others constructed like them. The systyle is a temple in which

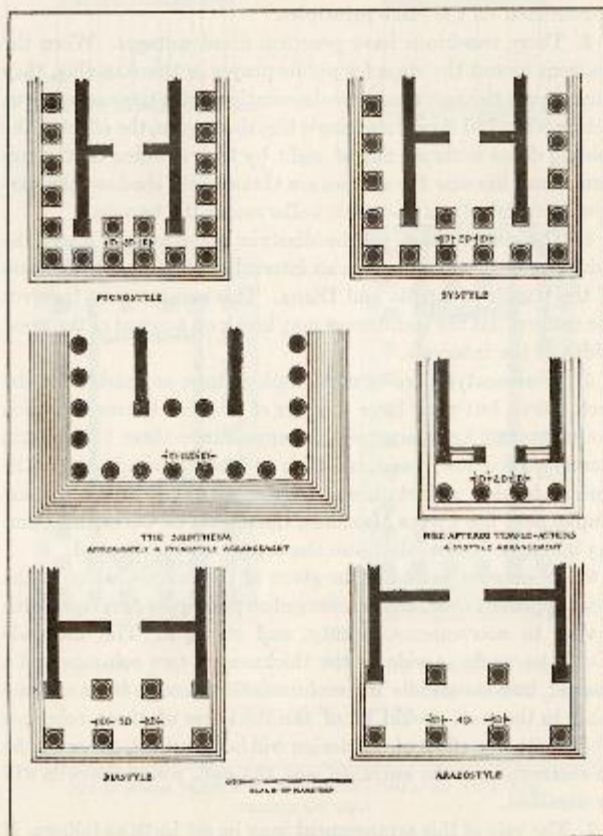

THE CLASSIFICATION OF TEMPLES ACCORDING TO INTERCOLUMNIATION

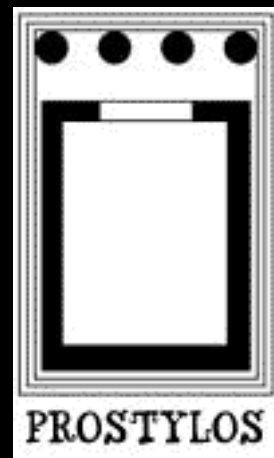



Temple of Portunus
Rome, Italy
3rd Century BCE



a C O L U M N is a freestanding support

a P I L A S T E R looks like a column
except that it is partially embedded
in the wall





Temple of Hercules Victor
Rome, Italy
2nd Century BCE





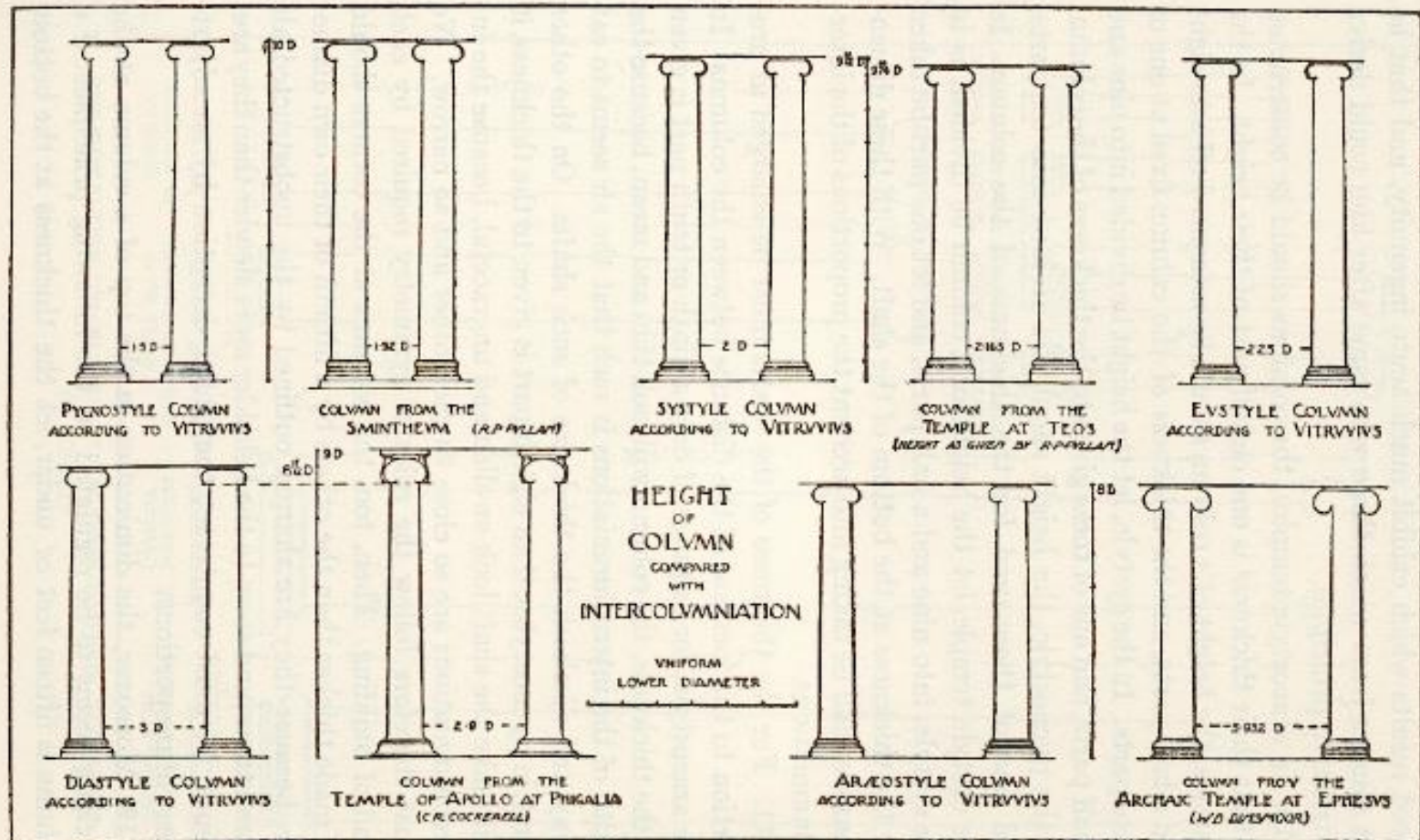

VITRUVIUS' RULES FOR THE DIAMETER AND HEIGHT OF COLUMNS IN THE DIFFERENT CLASSES OF TEMPLE COMPARED WITH ACTUAL EXAMPLES

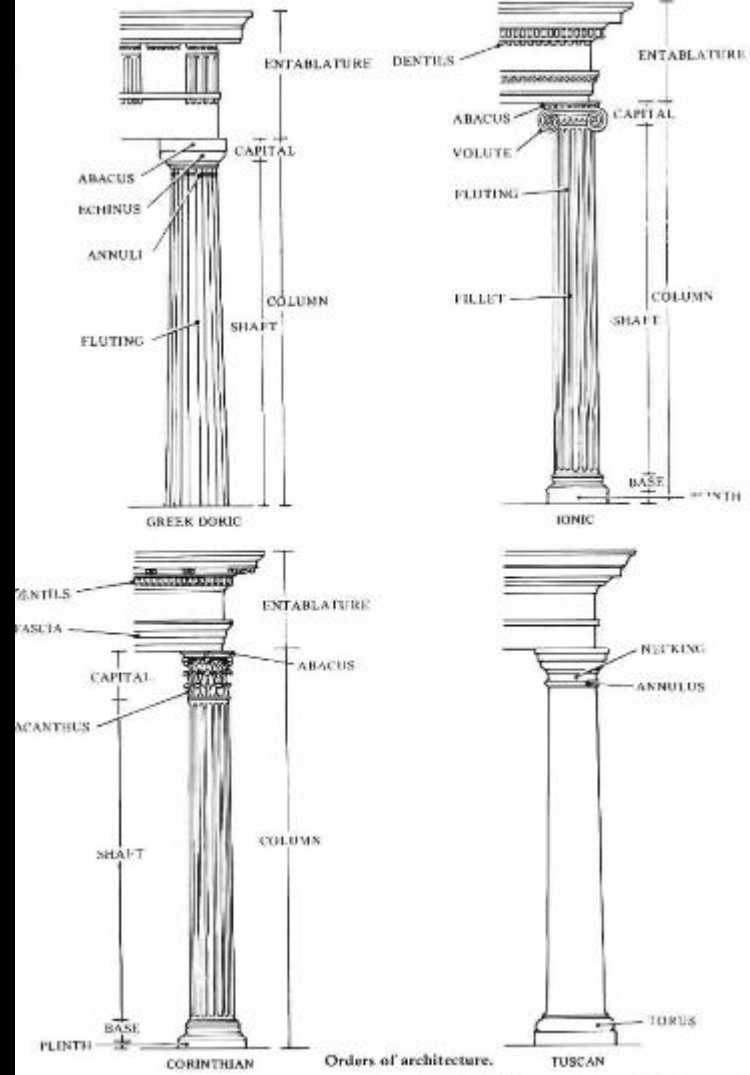
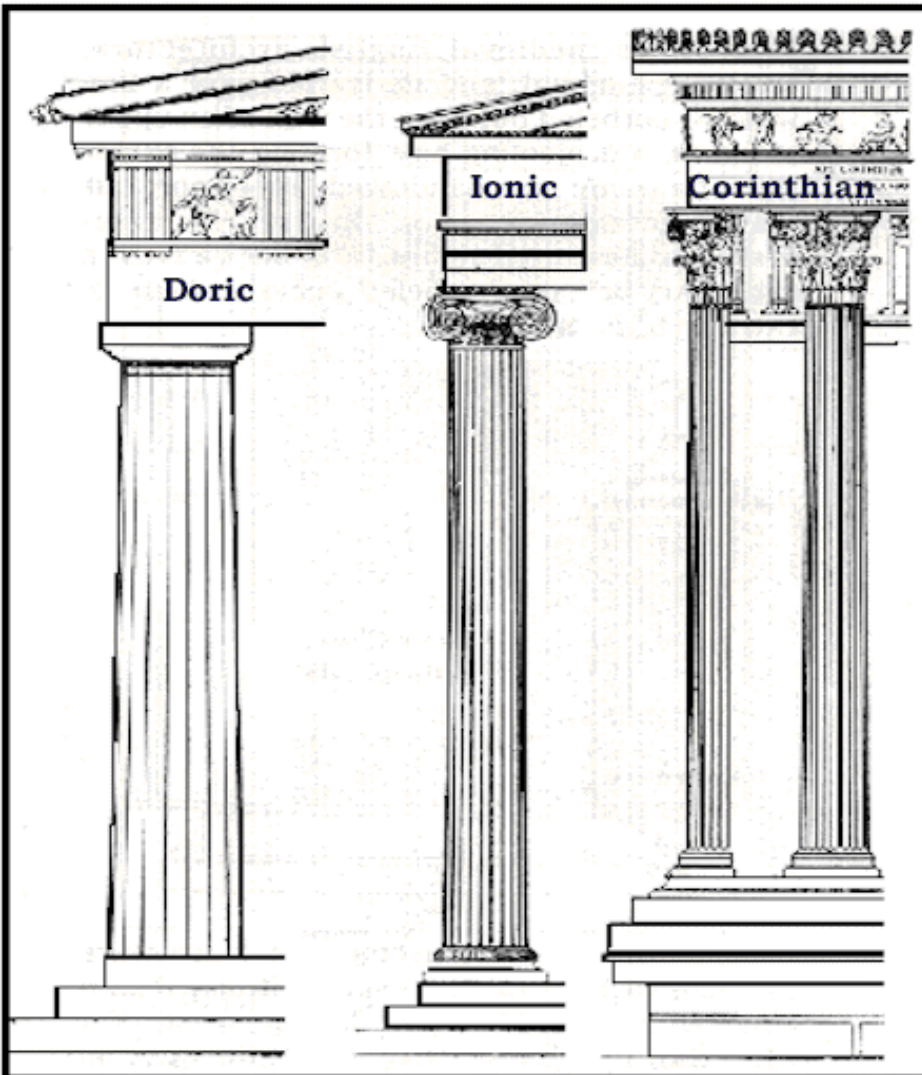

Orders of architecture.



Temple of Saturn
Roman Forum
497 BCE (contested)



